

# FITTING INSTRUCTIONS FOR FLEX-GRIP POLYETHYLENE AND STEEL PIPE COUPLINGS

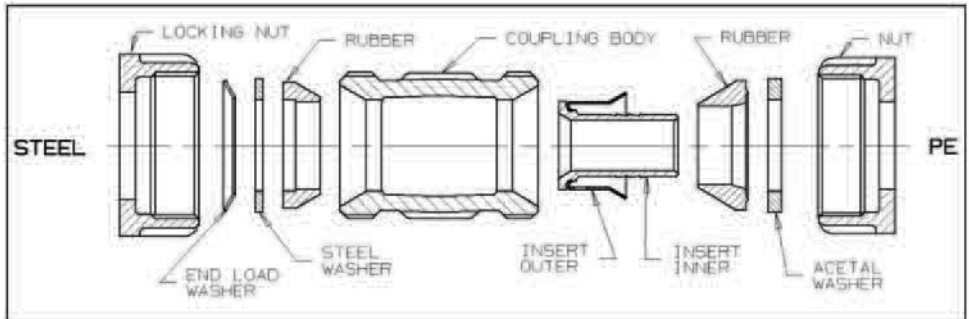

## PREPARATION OF THE PIPE ENDS

Polyethylene pipes should be free of external scratches and other damage. Cut square within 1mm and remove all burrs.

Where surface corrosion and/or debris are present on metallic pipes, this should be removed using a wire brush.

**Important:** Remove burrs on outside diameter

PIPE MATERIAL					* At temperatures below 5°C, tighten the 63mm fitting to the higher torque.
Steel		Steel pipe minimum insertion depth (mm)	Polyethylene (PE)		
O/D (ins)	Torque (Nm)		O/D (mm)	Torque (mm)	
1/2	55	30	20 SDR9	35	
3/4	70	30	25 SDR11	37	
1	105	30	32 SDR11	50	
1 1/4	130	30	-	-	
1 1/2	165	30	-	-	
2	200	35	63 SDR11	100	200*

## POLYETHYLENE PIPE

Clean any dirt from the end of the polyethylene pipe. Unscrew the end nut on the Flex-Grip Coupling and remove the steel/acetal washer and gasket and slide all three (in order) approximately 300mm down the cleaned length of the PE pipe. Remove the insert from the coupling and push onto the end of the pipe until the wall of the polyethylene becomes visible in the circular inspection hole of the insert.

Should the inner and outer insert parts become separated prior to assembly, ensure that the 'outer' is fitted on to the pipe before inserting the 'inner' into the pipe bore. Locate the PE pipe, complete with insert attached, back into the coupling body. Slide the gasket, steel/acetal ring and end nut back up the pipe and re-assemble. Tighten the end nut to the recommended torque.

## STEEL PIPE

Insert the end of the pipe into the coupling, ensuring that the end extends beyond the internal rubber seal (see table for minimum insertion depth). Tighten the end nut to the recommended torque value.

**Note:** It is not normally necessary to dismantle the steel end of the coupling. If however, the joint is dismantled, it must be assembled in the order as shown in the diagram. Ensure that the end load washer is fit the correct way.

### IMPORTANT INFORMATION

- Only use polyethylene pipe manufactured to GIS PL2 (PE80).
- When using a steel to polyethylene pipe coupling, ensure to insert the correct end into the coupling.
- When connecting metallic pipes, it is essential that a small relative movement between the pipe and fitting can occur during tightening.
- The steel locking joint will withstand the maximum working pressure of the polyethylene pipe (5.5 Bar).



To visit our Video Library go to:  
[www.youtube.com/user/CraneBSU](http://www.youtube.com/user/CraneBSU)



DELTA ROAD,  
ST HELENS, NWA9 2ED

TELEPHONE: +44 (0)1744 458649

FAX: +44 (0)1744 453675

EMAIL: [sales@wask-uk.com](mailto:sales@wask-uk.com)

[www.wask-uk.com](http://www.wask-uk.com)



FM311 ISO 9001

- Designed & manufactured under quality management systems in accordance with BS EN ISO 9001:2008

Every effort has been made to ensure that the information contained in this publication is accurate at the time of publishing. Crane Ltd assumes no responsibility or liability for typographical errors or omissions or for any misinterpretation of the information within the publication & reserves the right to change without notice.



[www.flowoffluids.com](http://www.flowoffluids.com)

Visit [www.flowoffluids.com](http://www.flowoffluids.com) to book your copy of the New Technical Paper 410.

CRANE

BUILDING SERVICES & UTILITIES

[www.cranepsu.com](http://www.cranepsu.com)

W\_PSP\_0313  
IOM\_JR0081\_V2